

COBRA
STUDIOS

COBRA STUDIOS —The SOLIDS collection

The solids collection is a family of dinner tables, coffee tables, side tables and light elements with a simple and sculptural design. The collection is inspired by the classical order of Roman architecture. A vocabulary of radical columns, walls and shapes that affirms the graphic design. Each piece is designed to be conceived as a sculptural entity within its environment.

The mix of heavy, solid legs and a thin soft top evokes a feeling of comfort and clemency. The supporting elements are so present, that they pierce through the table tops, marking the presence of what lays underneath. Their presence organises the tables. The top that used to be an element of priority, becomes merely a connecting piece. This ancillary function is emphasised by the matt, chalk finish.

The designs seek for contrast. The supports are heavy, yet transparent. Colourful yet cold. Hard, yet so soft. The distinct volumes can function as singular elements, but they decided to stay connected.

The intersecting and contrasting pieces, free-standing, will hit its mark in any interior.



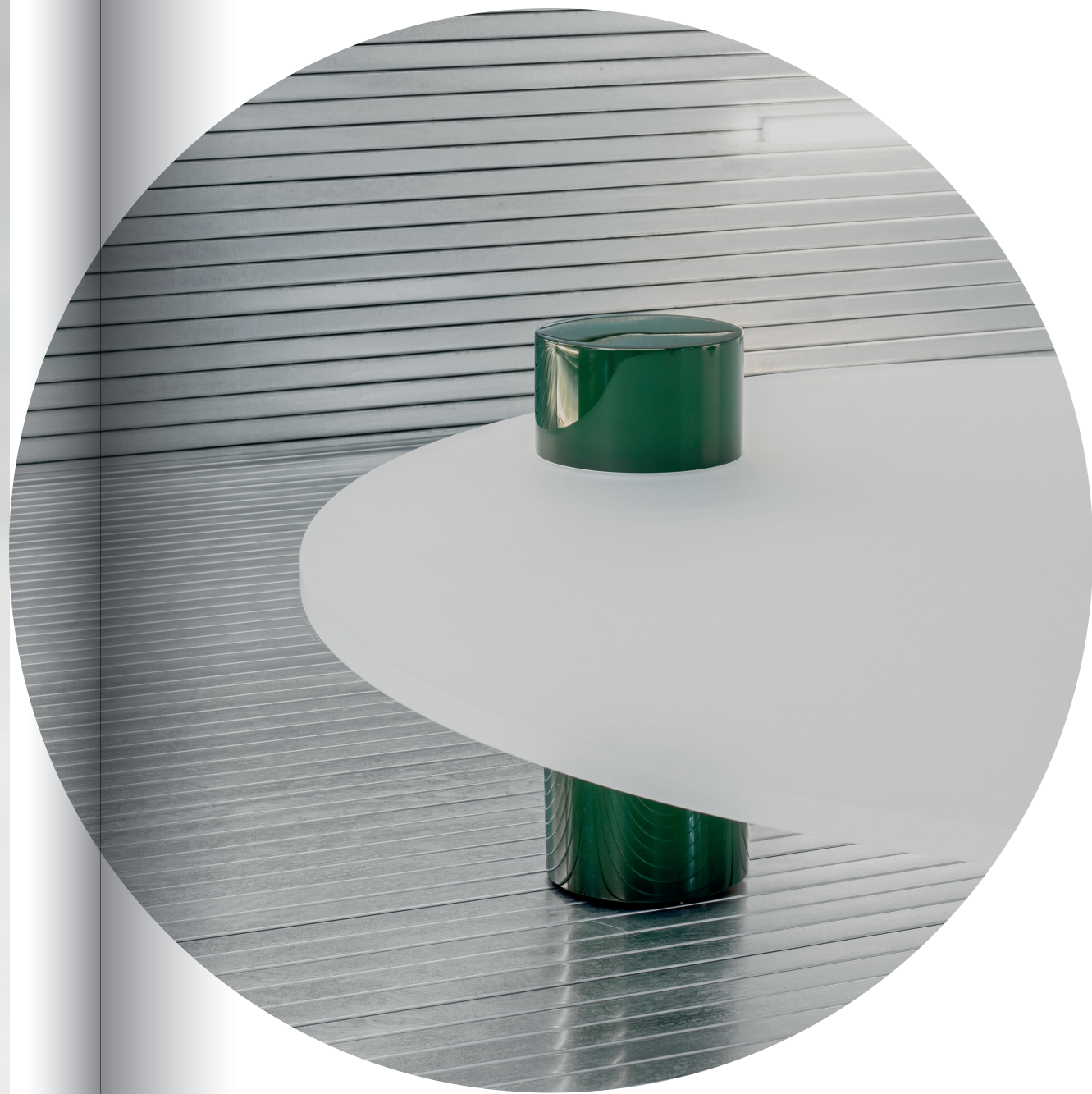
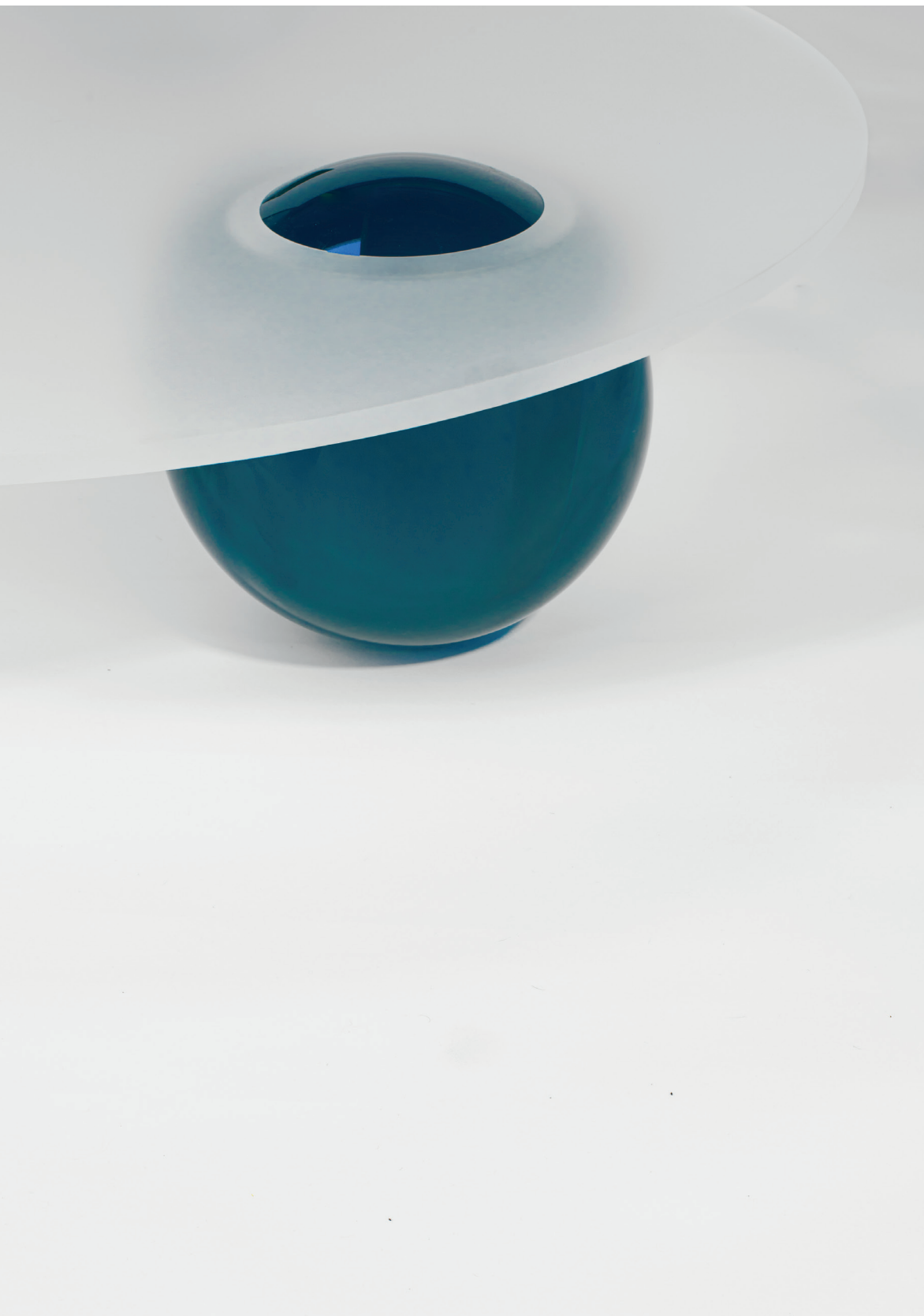



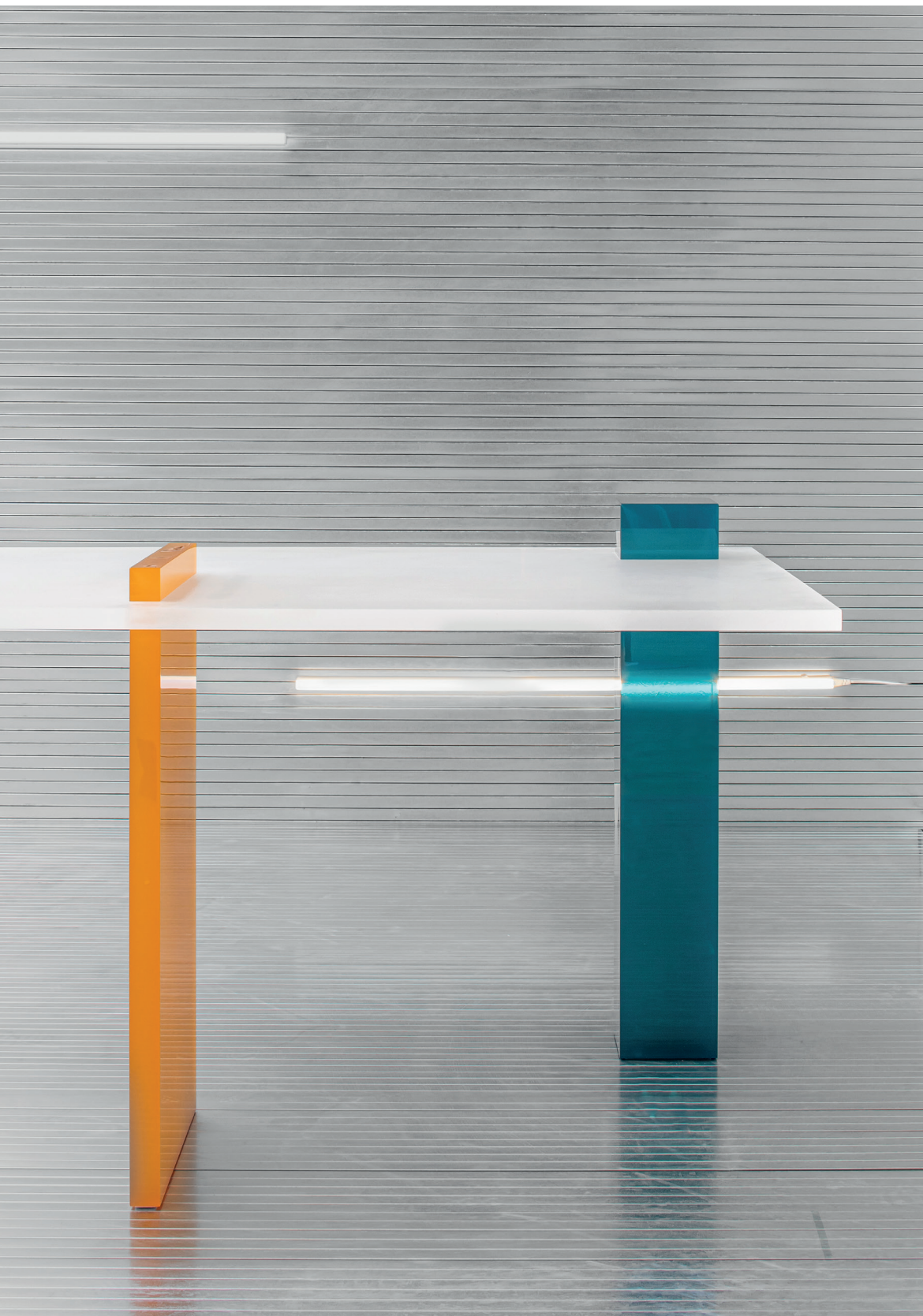



PRIAPE



OTHO



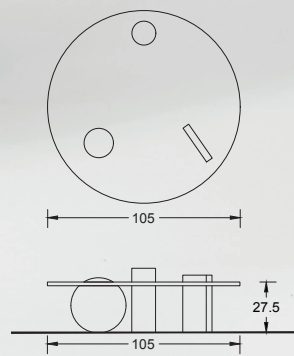
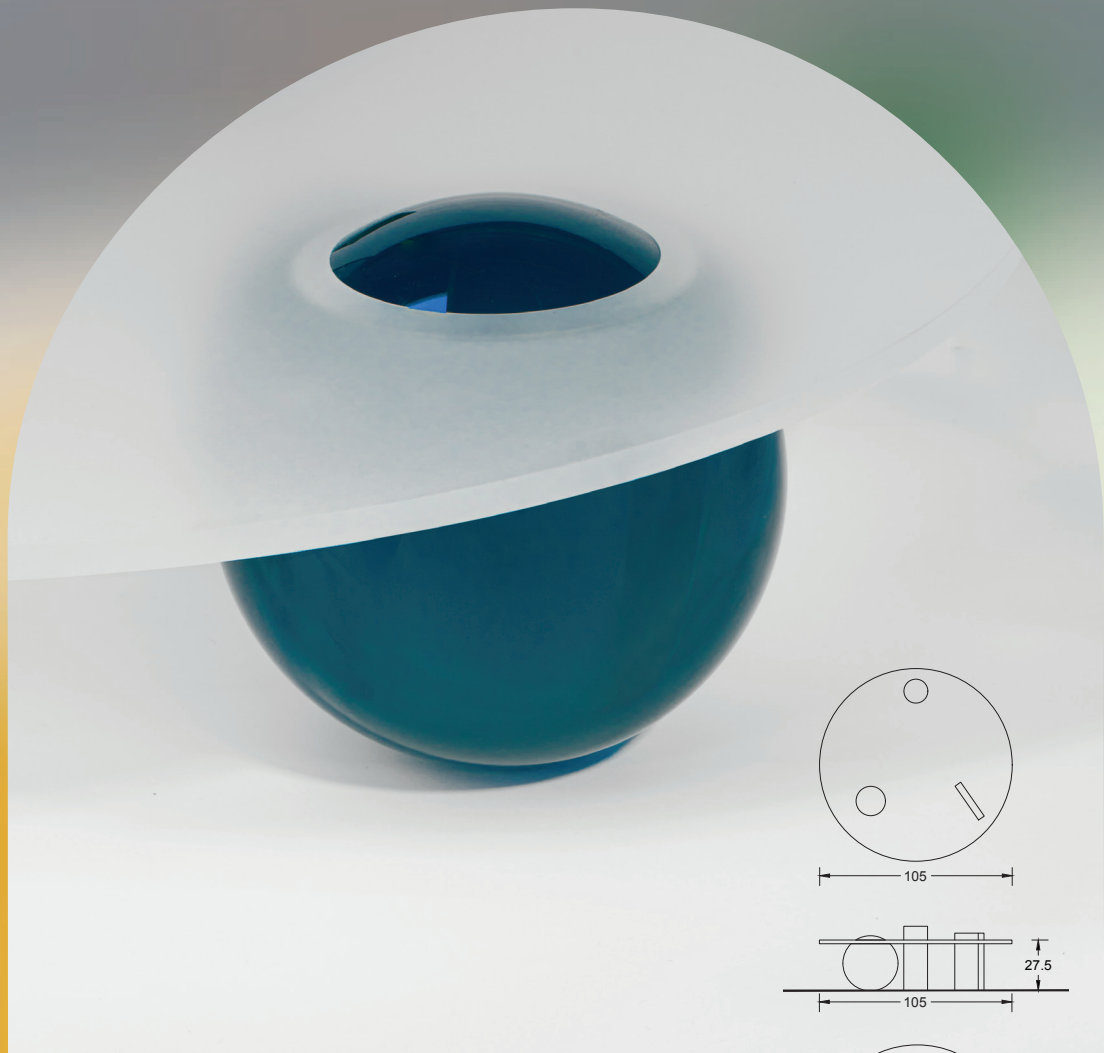

SANTA MARIA DEI CLARICI

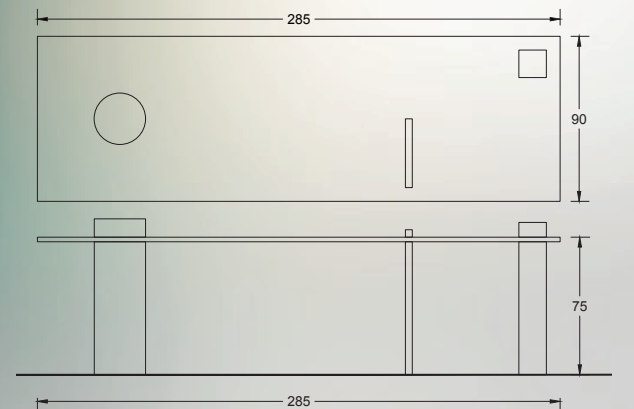
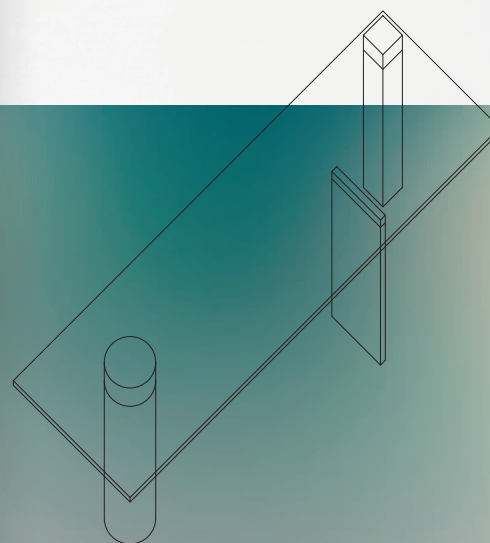

CICERO

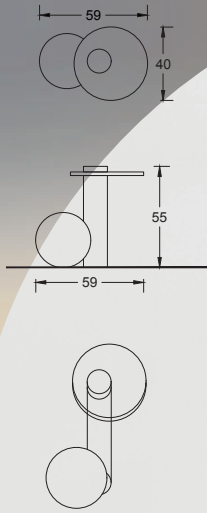

PRIAPE

Top	<input type="checkbox"/> Silk Grey <input type="checkbox"/> Bespoke: chose your finish
Legs	<input checked="" type="checkbox"/> Azure Green <input checked="" type="checkbox"/> Sapphire Blue <input type="checkbox"/> Honey Yellow <input type="checkbox"/> Nebbiollo d'alba Red <input type="checkbox"/> Bespoke: chose your colour

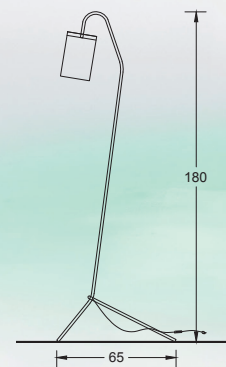
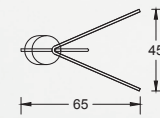

OTHO

Cobra studios is a Brussels based creative studio founded by Kenny Decommer and Hugues Delaunay. Cobra studios is created to counterbalance the current furniture and design scene. Based on a post-modernistic aesthetic, the goal is to collide geometrical shapes in order to create new usable volumetrics. Transparency, translucency and opacity are countered to create sculptural pieces. Contradiction is key, the world is boring, let's indulge the pieces with colour. Hard shapes need to collide with soft touches. The pieces need to be minimalistic yet very decorative. Every piece needs to withstand time and art movements. Cobra Studios tends towards creating a world of its own, a certain form of light living, naïve but such fun.

Kenny Decommer studied architecture and engineering at the university of Ghent. After graduating, he moved to Paris to get in touch with the creative scene. After several years of working as an architect, he returned to Brussels with the ambition to create and design pieces, no matter what they were.

Hugues Delaunay lives between Brussels and Paris, where he studied at the school of fine arts. Specialised in visual identity, visual merchandising and set design, he worked for several luxury fashion brands like Paul Smith, Chloé or Ralph Lauren. Together they created Cobra Studios.

Send an email to info@cobra-studios.com for more information.

COBRA

STUDIOS

RUE RENKIN 76 . B - 1030 BRUSSELS
INFO@COBRASTUDIOS.COM
WWW.COBRA-STUDIOS.DESIGN

CREATIVE DIRECTION
KENNY DECOMMER & HUGUES DELAUNAY
PHOTOGRAPHY JEROEN VERRECHT
GRAPHICS ELISE VERSTRAETE